



## SUMMARY

2T1513 is compactness and space-efficient which can use in small mechanism.

Suitable for IP Camera.

## USES

IP Camera/ Video Camera/ Surveillance Camera / CD or DVD Drive / Scanner / Label Printer

## DIMENSIONS:

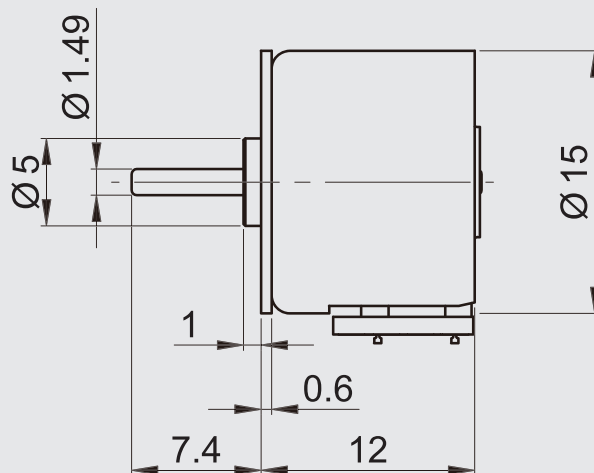
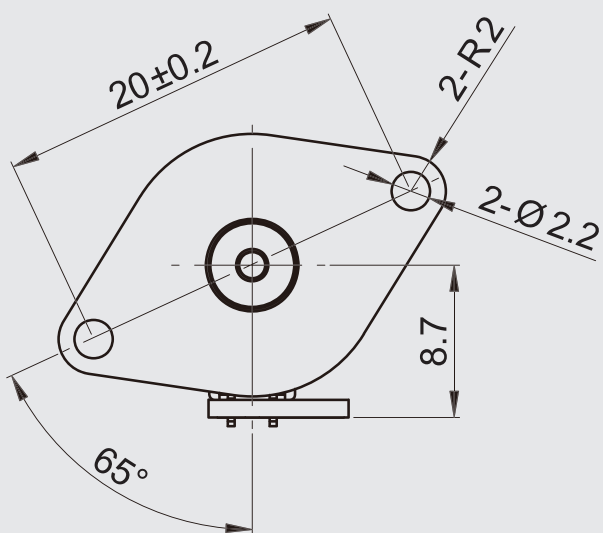

| Item                    | 2T1513                    |                             |
|-------------------------|---------------------------|-----------------------------|
| Standard voltage        | 5 V                       | 24 V                        |
| Standard Current        | 243 mA / Phase            | 200 mA / Phase              |
| Number of phase         | 4 phase                   | 4 phase                     |
| Step angles             | 18° / Step                | 18° / Step                  |
| Excitation              | 2-2 Bipolar               | 2-2 Bipolar                 |
| pull-out torque         | 10 g-cm or more / 816 pps | 8.6 g-cm or more / 2500 pps |
| pull-in torque          | 10 g-cm or more / 600 pps | 16 g-cm or more / 300 pps   |
| Holding torque          | 32 g-cm or more           | 25 g-cm or more             |
| Resistance per phase    | 9.4 Ω                     | 13.8 Ω                      |
| Max pull-out pulse rate | 1300 pps or more          | 5770 pps or more            |
| Max pull-in pulse rate  | 1000 pps or more          | 1000 pps or more            |

## CHARACTERISTICS:

### 5 V

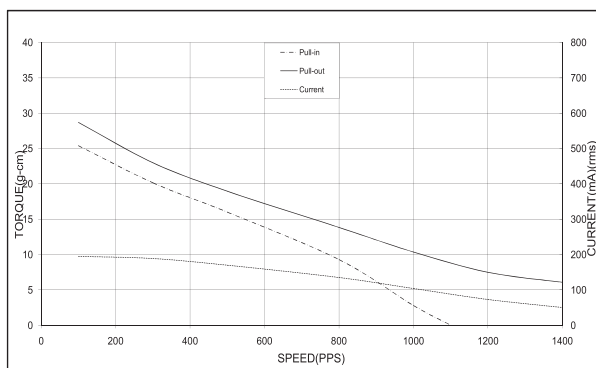

### 24 V

