 EXCEL CELL ELECTRONIC CO., LTD.	NO.	A31251		
	SPECIFICATION	Edition	3	Page

ECS - INDUSTRIAL CONTROL SWITCH EMERGENCY STOP (Ø16 TYPE)

1. FEATURES

- Pushlock turn reset function.
- Faston terminal #110 makes for easy connections.
- IP65 waterproof type. It is designed for liquid and oil prevention and enables to be used in different environment.
- In accordance with the standards of UL, cUL, CE, CCC, and TUV.
- Quick and easy assembly, just install into the mounting hole and lock the nut.

2. SPECIFICATIONS

2-1. ELECTRICAL

2-1-1. Rated thermal current	5A
2-1-2. Rated insulation voltage	250V
2-1-3. Utilization category	AC-15 or Ue 125V / Ie 3A Ue 250V / Ie 1.5 A DC-13 or Ue 30V / Ie 1A Ue 125V / Ie 0.22 A Ue 250V / Ie 0.1A
2-1-4. Minimum switching capacity [ref.]	5V DC/AC, 1mA
2-1-5. Dielectric strength	2500V AC, 1 min.
2-1-6. Insulation resistance	100MΩ min. at 500V DC
2-1-7. Contact resistance	50mΩ max. (initial)
2-1-8. Conditional short-circuit current	1000A
2-1-9 Short-circuit protective device	6A gG fuse

2-2. MECHANICAL AND ENVIRONMENTAL

2-2-1. Operating temperature	-25°C ~ +60°C (no freezing)
2-2-2. Storage temperature	-40°C ~ +80°C (no freezing)
2-2-3. Humidity	45% ~ 85% RH(no condensation)
2-2-4. Degree of protection	IP65 (from the front of the panel)
2-2-5. Degree of contamination	3 (IEC 60947-5-1)
2-2-6. Vibration resistance	10~500Hz single amplitude 0.35mm acceleration 50 m/s ²
2-2-7. Shock resistance	150 m/s ² (operating extremes) 1000 m/s ² (damage limits)
2-2-8. Mechanical Life	100,000 operations (10 operations/min.)
2-2-9. Electrical Life	100,000 operations (20 operations/ min.)
2-2-10. Operation Force (from 2b)[ref.]	14N
2-2-11. Operation travel	over 4 mm
2-2-12. Connection type	Faston terminal 2.8x0.5 mm
2-2-13. Direct opening action	Direct opening mechanism of NC contact to open the circuit ⊖

ECE	EXCEL CELL ELECTRONIC CO., LTD.	NO.		A31251	
		SPECIFICATION		Edition	3

3. PART NUMBERING SYSTEM

ECS – A 16 R E1 R M X – XX F

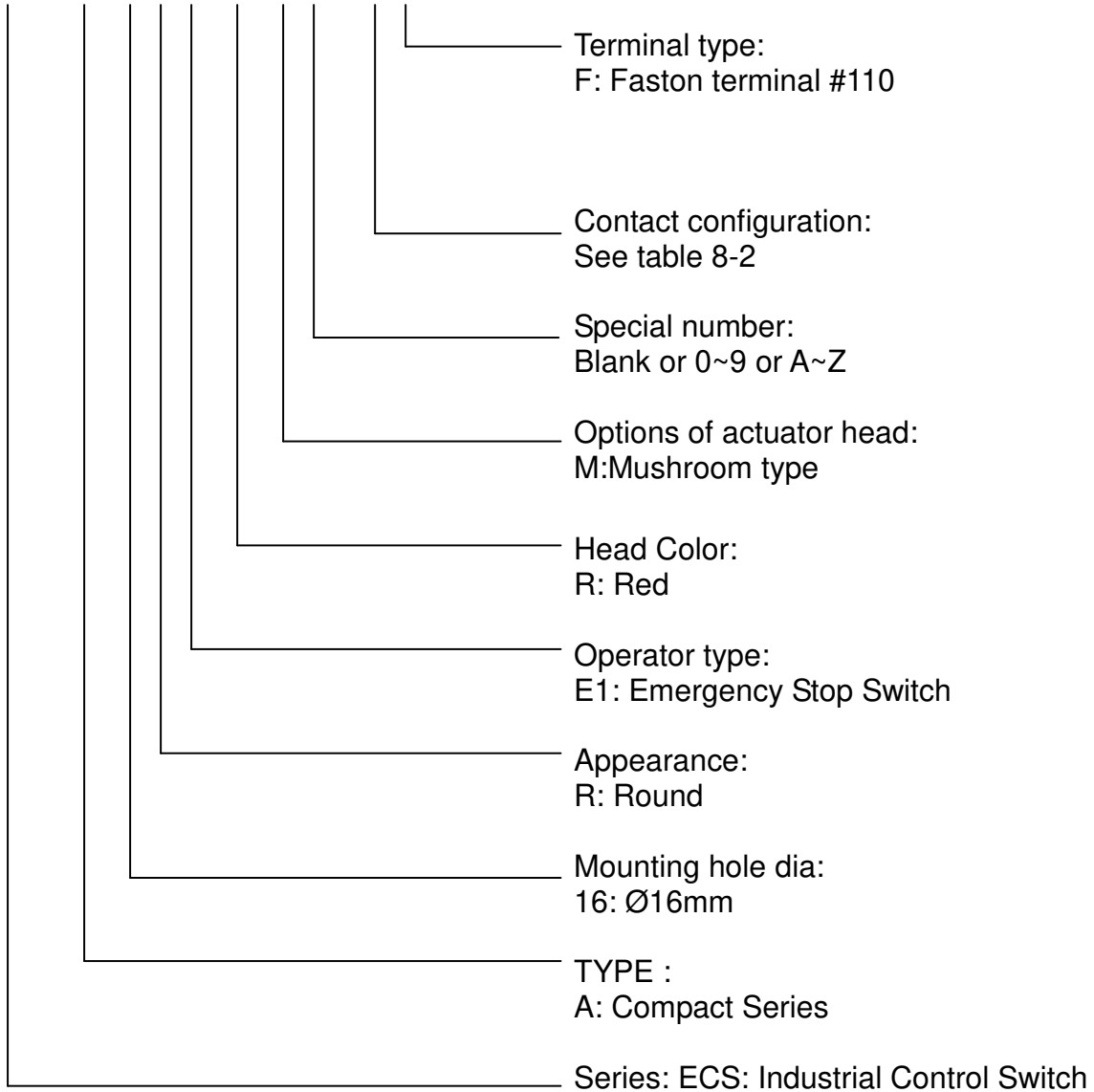

 EXCEL CELL ELECTRONIC CO., LTD.	NO.	A31251		
	SPECIFICATION	Edition	3	Page

4. INSTALLATION

4-1. Panel thickness

- The panel thickness must be 1 to 4 mm.
- Take into consideration about the thickness of accessories (such as name plate, switch guard, etc.) while using.

4-2. Panel cutout

- Cutout diameter and distance

Unit: mm

	16R
$\varnothing A$	16.2 $\begin{matrix} +0.2 \\ -0 \end{matrix}$
X	40
Y	40
a	17.9 $\begin{matrix} +0.2 \\ -0 \end{matrix}$
b	1.7 $\begin{matrix} +0.2 \\ -0 \end{matrix}$

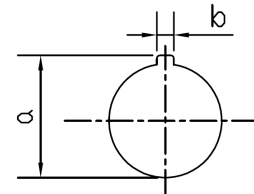
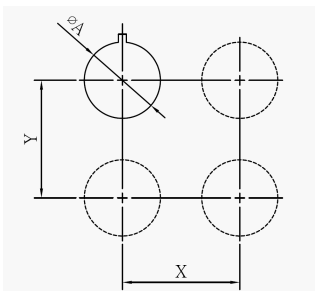

■ Panel installation

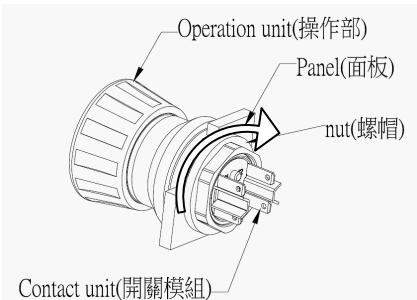
	<ol style="list-style-type: none"> 1. Place the operation unit through panel mounting hole. 2. Install the nut by using tightening tool. 3. Make sure the operation unit fix on the panel firmly.
---	--

5. PACKAGING

5-1. ECS product is packed 1 pcs/bag, 20 bags per box.

5-2. Label information

- | | |
|-------------------|-------------------------|
| (1) Part number | (6) QC inspection stamp |
| (2) Lot number | (7) Company mark |
| (3) Quantity | (8) Company name |
| (4) Tester number | (9) Notice |
| (5) Date code | |

6. DIMENSIONS

See attached drawings

 EXCEL CELL ELECTRONIC CO., LTD.	NO.	A31251		
	SPECIFICATION	Edition	3	Page

7. OPTIONS

7-1. For other accessories (name plate, control box, and etc.), please refer to accessor part in the catalog.

8. REMARK

8-1. Safety Certification

Safety Standard	Certification
UL-508	Pending
CSA C22.2 NO.14	
EN60947-5-1	R50457863
EN60947-5-5 (Emergency Stop Switch)	
CCC GB14048.5	2021000305000217

8-2. Contact Configuration

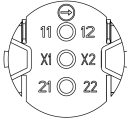
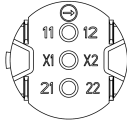
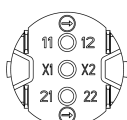
Code	Contact blocks		Layout diagram
	NO	NC	
01	0	1	
11	1	1	
02	0	2	

8-3. CAUTION

- To prevent injury, this device must be disconnected from all power sources prior to wiring and other initiating work.
- Use tightening tool when installing the operation unit in the panel cutout. Do not use pliers and do not tighten excessively, otherwise the operation unit may be damaged.

ECS-A16RE1RXX-01F

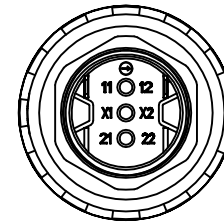
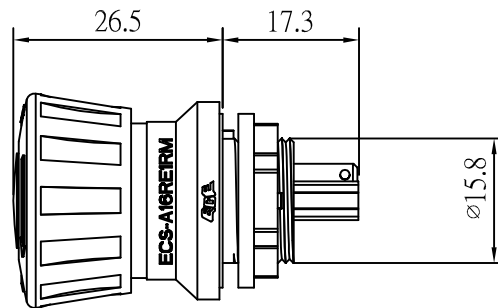
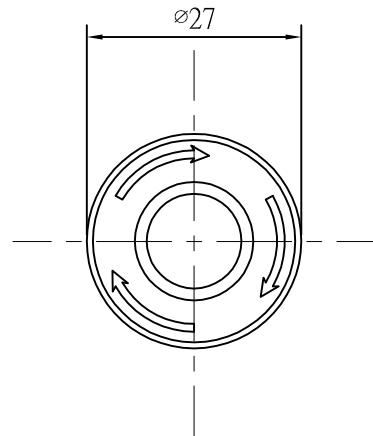
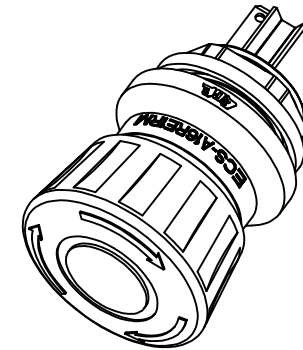
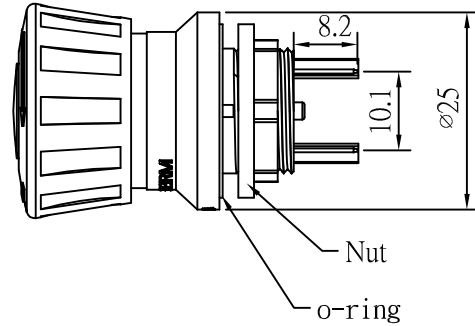

NOTE:

1.CONNECT TYPE:

Faston terminals #110 2.8 x 0.5mm

2.Panel thickness 1~4mm.

3.Operation travel : over 4mm

4.Contact configuration :

Code	Contact black		Layout diagram
	NO	NC	
01	0	1	

				NORMAL TOLERANCE		EXCEL CELL ELECTRONIC CO., LTD.				PART NUMBER		ECS-A16RE1RXX-01F					
				RANGE	TOLERANCE					UNIT	MM (INCH)	PART NAME	ECS(φ16)				
				0-1	±0.1	CHECK	Gary Kuo	DESIGN	Alice Lin	DRAWN	Alice Lin	SCALE	1:1	TYPE	Emergency		
				1-4	±0.3							SIZE	A4	FILE NAME	769A16RE1RXXXXFA.DWG		
				4-16	±0.5							PROJECTION		EDITION	A		
				16-63	±0.8												
				63-250	±1.0												
				X.	±5°												
NO.	DETAILS	ALTERED BY	DATE	X.X	±2.5°												

ECS-A16RE1RXX-02F

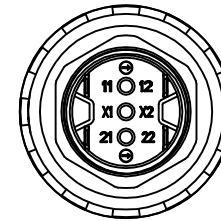
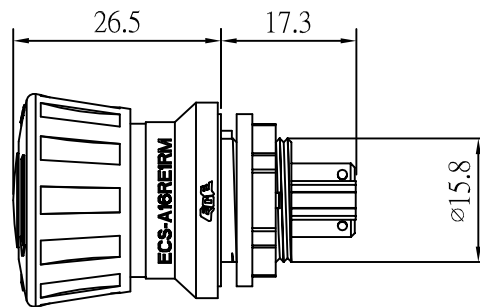
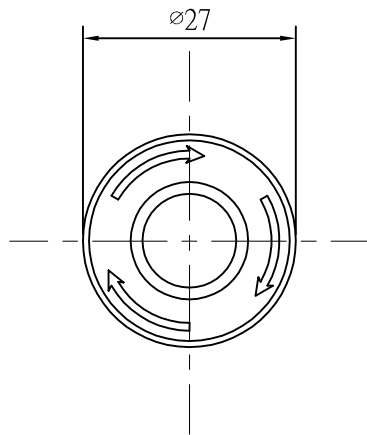
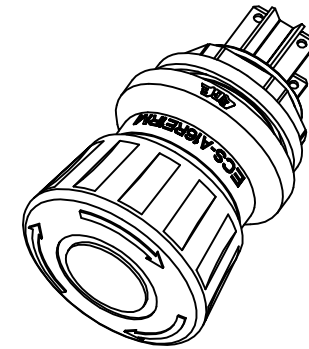
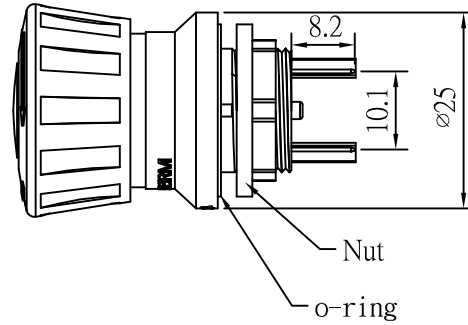

NOTE:

1.CONNECT TYPE:

Faston terminals #110 2.8 x 0.5mm

2.Panel thickness 1~4mm.

3.Operation travel : over 4mm

4.Contact configuration :

Code	Contact black		Layout diagram
	NO	NC	
02	0	2	

NO.	DETAILS	ALTERED BY	DATE	NORMAL TOLERANCE		CHECK	DESIGN	DRAWN	UNIT	PART NUMBER	PART NAME	
				RANGE	TOLERANCE						MM (INCH)	TYPE
				0-1	± 0.1	EXCEL CELL ELECTRONIC CO., LTD.	Gary Kuo	Alice Lin	Alice Lin	MM (INCH)	ECS-16RE1RXX-02F	ECS($\varnothing 16$)
			1-4	± 0.3	SCALE					1:1	TYPE	Emergency
			4-16	± 0.5	SIZE					A4	FILE NAME	769A16RE1RXXXXFA.DWG
			16-63	± 0.8	PROJECTION						EDITION	A
			63-250	± 1.0								
			X.	$\pm 5^\circ$								
			X.X	$\pm 2.5^\circ$								

ECS-A16RE1RXX-11F

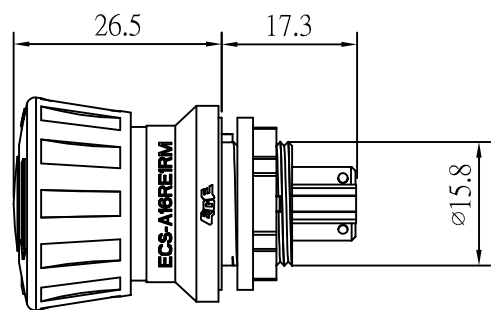
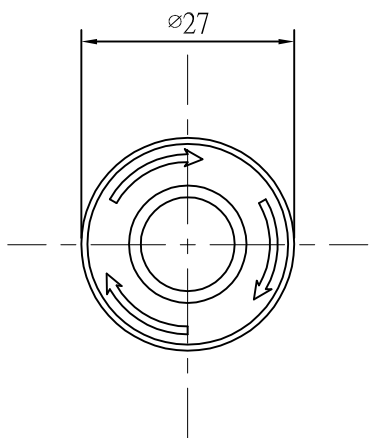
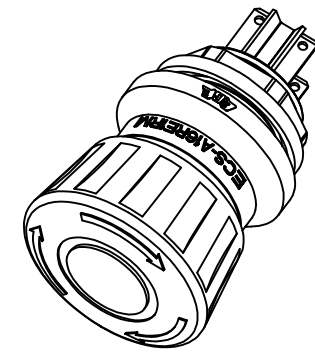
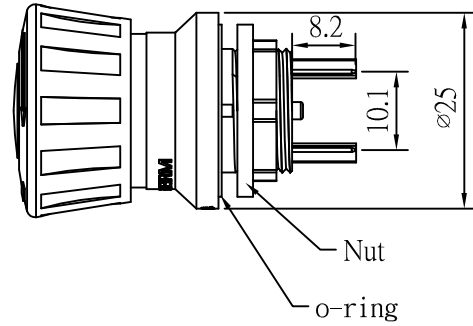

NOTE:

- 1.CONNECT TYPE:
Faston terminals #110 2.8 x 0.5mm
- 2.Panel thickness 1~4mm.
- 3.Operation travel : over 4mm
- 4.Contact configuration :

Code	Contact black		Layout diagram
	NO	NC	
02	1	1	

NO.	DETAILS	ALTERED BY	DATE	NORMAL TOLERANCE		CHECK	DESIGN	DRAWN	UNIT	PART NUMBER	PART NAME				
				RANGE	TOLERANCE						MM (INCH)	TYPE			
				0-1	±0.1	Gary Kuo	Alice Lin	Alice Lin	MM (INCH)	ECS-A16RE1RXX-11F	PART NAME	ECS(φ16)			
			1-4	±0.3	SCALE				1:1		TYPE	Emergency			
			4-16	±0.5	SIZE				A4		FILE NAME	769A16RE1RXXXXFA.DWG			
			16-63	±0.8	PROJECTION						EDITION	A			
			63-250	±1.0											
			X.	±5°											
			X.X	±2.5°											

EXCEL EXCEL CELL ELECTRONIC CO., LTD.