



NEOCENE

2A1513 | SPECIFICATION



SUMMARY

Small Motor is Converted to High Output Torque via a Gear Box
Customizable Gearbox Deceleration Ratio

USES

LED Light Control
Driving Recorder & Navigation
Projector
Automatic Inspection Equipment
Medical Equipment

➤ DIMENSIONS :

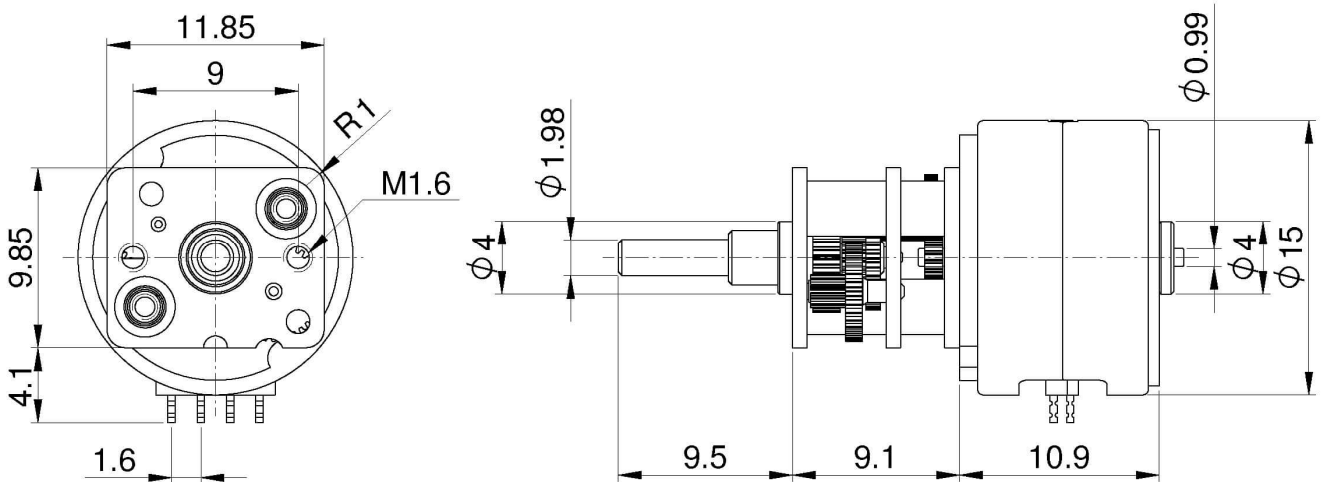



NEOCENE

2A1513 | SPECIFICATION

Item	2A1513
Standard voltage	9V
Standard Current	300 mA/Phase
Number of phase	4 Phase
Step angles	18° / Step(Output shaft 0.18° / Step)
Transmission ratio	1:100 (customization)
Excitation	2-2 Bipolar
Pull-out torque	1.0 kg-cm or more / 500 pps
Holding torque	1.5 kg-cm or more
Resistance per phase	10 Ω
Max pull-out pulse rate	1000 pps or more
Max pull-in pulse rate	300 pps or more

➤ CHARACTERISTICS :

9V

